

PMC-230

Single-Phase Multifunction Meter

User Manual

Version: V1.1

April 1, 2022



This manual may not be reproduced in whole or in part by any means without the express written permission from CET Electric Technology (CET).

The information contained in this Manual is believed to be accurate at the time of publication; however, CET assumes no responsibility for any errors which may appear here and reserves the right to make changes without notice. Please consult CET or your local representative for latest product specifications.

Standards Compliance



DANGER

This symbol indicates the presence of danger that may result in severe injury or death and permanent equipment damage if proper precautions are not taken during the installation, operation or maintenance of the device.



CAUTION

This symbol indicates the potential of personal injury or equipment damage if proper precautions are not taken during the installation, operation or maintenance of the device.



DANGER

Failure to observe the following instructions may result in severe injury or death and/or equipment damage.

- Installation, operation and maintenance of the meter should only be performed by qualified, competent personnel that have the appropriate training and experience with high voltage and current devices. The meter must be installed in accordance with all local and national electrical codes.
- Ensure that all incoming AC power and other power sources are turned OFF before performing any work on the meter.
- Before connecting the meter to the power source, check the label on top of the meter to ensure that it is equipped with the appropriate power supply, and the correct voltage and current input specifications for your application.
- During normal operation of the meter, hazardous voltages are present on its terminal strips and throughout the connected potential transformers (PT) and current transformers (CT). PT and CT secondary circuits are capable of generating lethal voltages and currents with their primary circuits energized. Follow standard safety precautions while performing any installation or service work (i.e. removing PT fuses, shorting CT secondaries, ...etc).
- Do not use the meter for primary protection functions where failure of the device can cause fire, injury or death. The meter should only be used for shadow protection if needed.
- Under no circumstances should the meter be connected to a power source if it is damaged.
- To prevent potential fire or shock hazard, do not expose the meter to rain or moisture.
- Setup procedures must be performed only by qualified personnel familiar with the instrument and its associated electrical equipment.
- **DO NOT** open the instrument under any circumstances.

Limited warranty

- CET Electric Technology (CET) offers the customer a minimum of 12-month functional warranty on the meter for faulty parts or workmanship from the date of dispatch from the distributor. This warranty is on a return to factory for repair basis.
- CET does not accept liability for any damage caused by meter malfunctions. CET accepts no responsibility for the suitability of the meter to the application for which it was purchased.
- Failure to install, set up or operate the meter according to the instructions herein will void the warranty.
- Only CET's duly authorized representative may open your meter. The unit should only be opened in a fully anti-static environment. Failure to do so may damage the electronic components and will void the warranty.

Glossary

COM / Comm.	= Communication
CT	= Current Transformer
DI / DO	= Digital Input / Output
FP	= Front Panel
Imp. / Exp.	= Import / Export
MB	= Mega Byte
MBPW	= Modbus Password
NER	= National Electricity Rules
NMI	= National Measurement Institute
PF	= Power Factor
PPS	= Pulse Per Second
RMS	= Root Mean Square
RTC	= Real-Time Clock
SCADA	= Supervisory Control And Data Acquisition
SOE	= Sequence of Events
T1 to T4	= Tariff 1 to Tariff 4
THD	= Total Harmonics Distortion
TOU	= Time of Use
UL	= Underwriters Laboratories Inc.
WAGES	= Water, Air, Gas, Electricity and Steam

Table of Contents

Chapter 1 Introduction	1
1.1 Overview	1
1.2 Features	1
1.3 PMC-230's application in Power and Energy Management System	2
1.4 Getting More Information	2
Chapter 2 Installation	3
2.1 Appearance	3
2.2 Terminal Dimensions	3
2.3 Unit Dimensions.....	4
2.4 Installations.....	4
2.5 RS-485 Wiring	5
2.6 Digital Input	5
2.7 Pulse Output	5
Chapter 3 Front Panel	6
3.1 LCD Display	6
3.1.1 LED Pulse Output	6
3.1.2 LCD Display Symbols	6
3.2 LCD Testing.....	6
3.3 Display Modes.....	6
3.4 Data Display	7
3.5 Setup Configuration via the Front Panel	8
3.5.1 Function of buttons	8
3.5.2 Setup Menu	9
3.5.3 Configurations.....	10
Chapter 4 Applications.....	11
4.1 Inputs and Outputs	11
4.1.1 Digital Inputs	11
4.1.2 Energy Pulse / 1 PPS Output	11
4.1.3 Disconnect Relay	11
4.2 Metering	11
4.2.1 Basic Measurements.....	11
4.2.2 Energy Measurements	11
4.2.3 Demands	11
4.2.4 Harmonics.....	12
4.3 Logs	12
4.3.1 Monthly Energy Log	12
4.3.2 SOE Log	13
4.3.3 Data Recorder Log.....	13
4.4 Time of Use (TOU).....	14
Chapter 5 Modbus Map	15
5.1 Basic Measurements.....	15
5.2 Real Time Energy Measurements	16
5.3 DI Pulse Counter	16
5.4 Harmonic Measurement.....	16
5.5 Demand Measurements	16
5.5.1 Present Demand	16
5.5.2 Max. Demand of This Month (Since Last Reset)	16
5.5.3 Max. Demand of Last Month (Before Last Reset)	17
5.5.4 Demand Data Structure	17
5.6 Logs	17
5.6.1 Monthly Energy Log	17
5.6.2 Data Recorder Log.....	17
5.6.3 SOE Log	18
5.7 Device Setup	20
5.7.1 Basic Setup.....	20

5.7.2 I/O Setup	21
5.7.3 Communication Setup	21
5.8 TOU Setup	21
5.8.1 Basic	21
5.8.2 Seasons	22
5.8.3 Daily Profile.....	22
5.8.4 Alternate Days.....	23
5.9 Data Recorder Setup	23
5.10 Time	24
5.11 Remote Control.....	25
5.12 Clear/Reset Control.....	25
5.13 Meter Information	25
Appendix A – Technical Specification	27
Appendix B – Standards of Compliance	28
Appendix C – Ordering Guide	29
Contact us	30

Chapter 1 Introduction

This manual explains how to use the PMC-230 Single-Phase Multifunction Meter.

This chapter provides an overview of the PMC-230 meter and summarizes many of its key features.

1.1 Overview

The PMC-230 Single-Phase Multifunction Meter is CET's latest offer for the low voltage energy metering market featuring DIN rail mount, compact construction, 63A direct input with an internal UC3 Disconnect Relay compliant with Australia National Electricity Rules (NER) schedule 7.5 for the ability to disconnect/re-connect from the supply. The PMC-230 also complies with the IEC 62053-21 Class 1 kWh Accuracy Standard and has received the certificate of approval from the National Measurement Institute (NMI) of Australia for compliance with the M6-1 Electricity Meters, Part 1: Metrological and Technical Requirements. The PMC-230 provides 4MB Log Memory for Data Recording, 3xDI for Status Monitoring or Pulse Counting, 1xLED Pulse Indicator and 1xSS Pulse Output for Energy Pulsing. Further, the standard RS-485 port supporting Modbus RTU protocol with password protection allows the PMC-230 to become a vital component of an intelligent, multifunction monitoring solution for any Energy Management Systems.

Following is a list of typical applications for the PMC-230:

- DIN rail mount energy metering
- Industrial, Commercial and Utility Substation Metering
- Building, Factory and Process Automation
- Sub-metering and Cost Allocation
- NMI compliant Energy Management

Contact CET Technical Support at support@cet-global.com should you require further assistance with your application.

1.2 Features

Ease of Use

- Easy to read LCD for both data viewing and configuration
- Two LED indicators for Energy Pulsing and Disconnect Relay status
- Password-protected setup via Front Panel or free PMC Setup software
- Easy installation with DIN rail mounting, no tools required

Basic Measurements

- IEC 62053-21 Class 1 and NMI M6-1 Certified by UL
- Direct Input up to 63A without external CT
- U, I, P, Q, S, PF, Frequency and Operating Time
- kWh and kvarh Imp./Exp and kVAh
- Two TOU schedules, each providing
 - 4 Seasons
 - 12 Daily Profiles, each with 8 Periods in 15-minute interval
 - 30 Holidays or Alternate Days
 - 4 Tariffs, each providing kWh/kvarh Imp./Exp., kVAh
- Demands and Max. Demands for U, I, P/Q/S with Timestamp for This Month & Last Month (or Since Last Reset & Before Last Reset)
- U and I THD
- DI Counters, Front Panel & Communication Programming Counters

Disconnect Relay (Internal)

- UC3 compliant Disconnect Relay that can be activated locally from the Front Panel or remotely via communications

Energy Pulse Outputs

- 1 LED Energy Pulse Output on the Front Panel
- 1 Solid State Relay Energy Pulse Output

Digital Inputs

- 3 channels for external status monitoring and pulse counting
- Self-excited, internally wetted at 12VDC
- 1000Hz sampling

Data Recorder

- One Data Recorder Log of 16 parameters
- Recording Interval from 1 second to 40 days.
- Configurable Depth (max. 65535) and Recording Offset
- 4MB Log Memory, capable of recording 16 parameters at 5-minute interval for 6 months
- Available parameters: U, I, P, Q, S, PF, Freq., kWh Imp./Exp., kvarh Imp./Exp., Demands and Max. Demands for U, I, P/Q/S Total, DI Pulse Counters and Relay Status

Monthly Energy Log

- 12 historical monthly logs of kWh/kvarh Imp./Exp. and kVAh as well as kWh/kvarh Imp./Exp. and kVAh per Tariff

SOE Log

- 32 events time-stamped to ±1ms resolution

Communications

- Optically isolated RS-485 port at 1200 to 19,200 bps
- Modbus RTU protocol with configurable password protection

Real-time Clock

- Battery backed RTC @ 6ppm (≤0.5s/day)
- Battery Life > 10 years

System Integration

- Supported by our PecStar® iEMS and PMC Setup
- Easy integration into other Automation or SCADA systems via Modbus RTU protocol

1.3 PMC-230's application in Power and Energy Management System

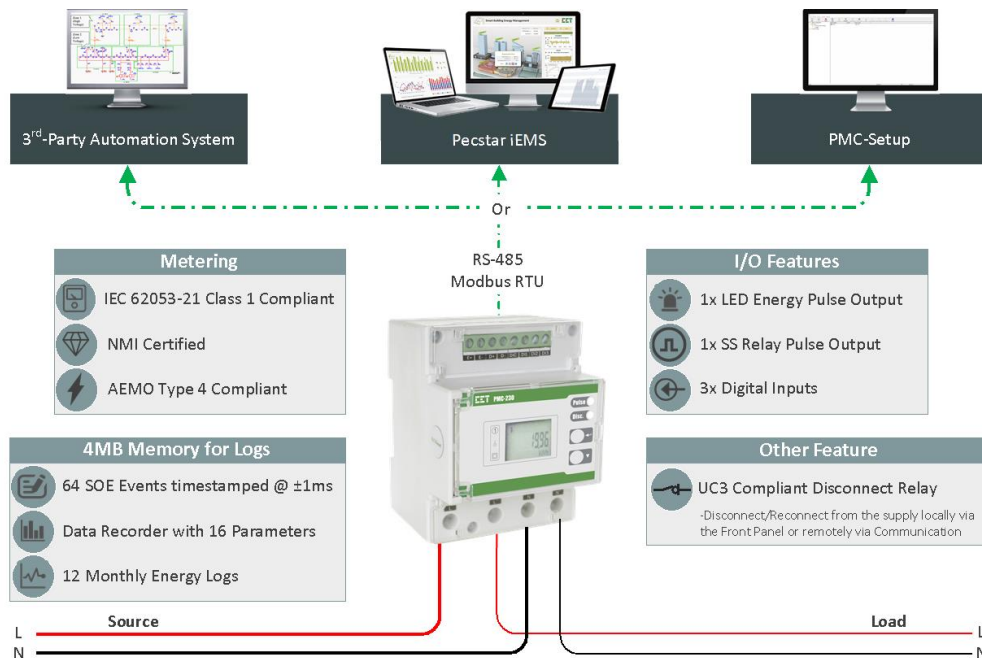

Figure 1-1 Typical Application

1.4 Getting More Information

Additional information is available from CET via the following sources:

- Visit www.cet-global.com
- Contact your local representative
- Contact CET directly via email or telephone

Chapter 2 Installation



Caution

Installation of the PMC-230 should only be performed by qualified, competent personnel that have the appropriate training and experience with high voltage and current devices. The meter must be installed in accordance with all local and national electrical codes.

During the operation of the meter, hazardous voltages are present at the input terminals. Failure to observe precautions can result in serious or even fatal injury and equipment damage.

2.1 Appearance

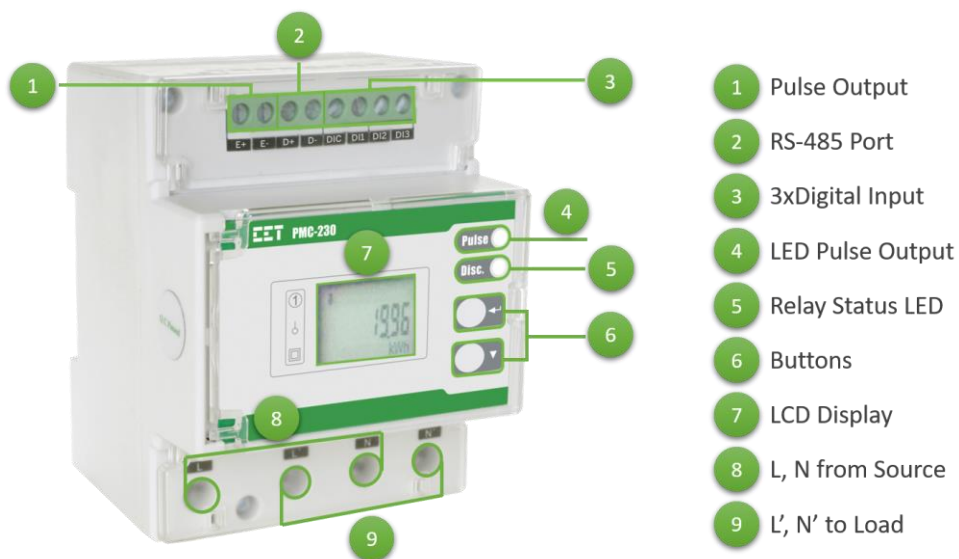

Figure 2-1 Appearance

2.2 Terminal Dimensions

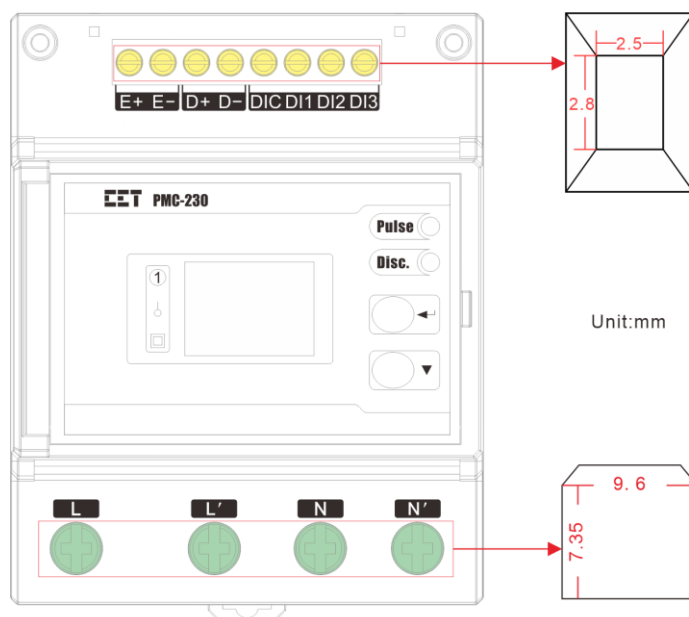
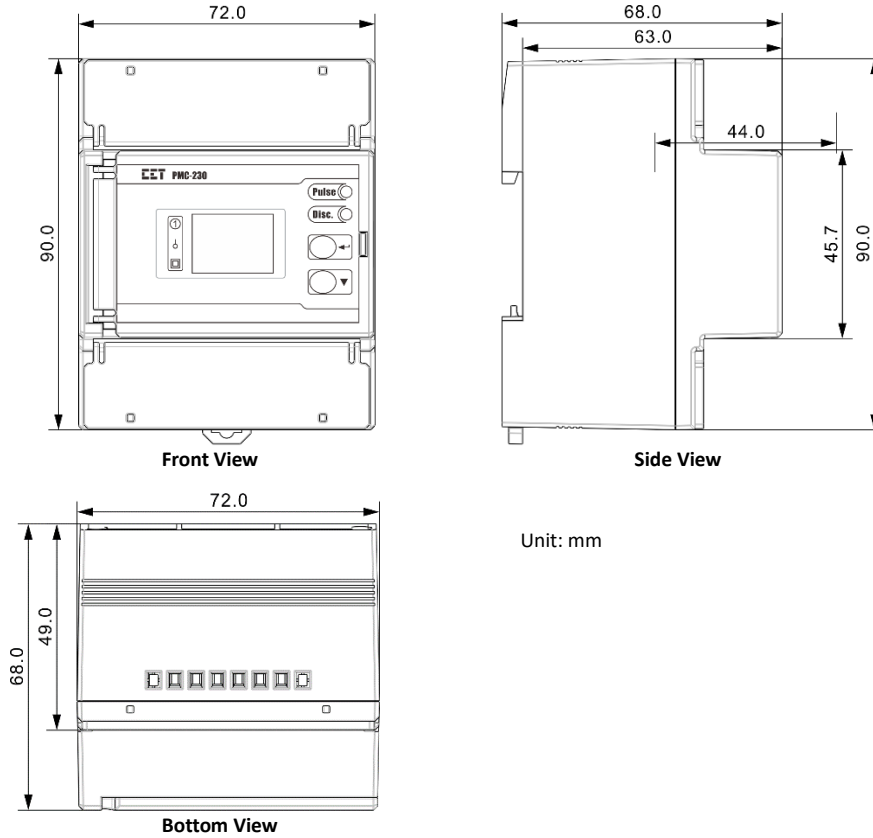

Figure 2-2 Terminal Dimensions

	Terminal	Terminal Dimensions	Max. Wire Size	Max. Torque
1	Input (L, N)	7.35mm x 9.6mm	25.0mm ²	25.0 kgf.cm/M3 (21.7 lb-in)
2	Output (L, N')			
3	Pulse Output (E+, E-)	2.5mm x 2.8mm	1.5mm ²	4.5 kgf.cm/M3 (3.9 lb-in)
4	RS-485 (D+, D-)			
5	DI (DIC, DI1, DI2, DI3)			

Figure 2-3 Terminal Dimensions

2.3 Unit Dimensions



2.4 Installations

The PMC-230 should be installed in a dry environment with no dust and kept away from heat, radiation and electrical noise source.

Installation steps:

- Before installation, make sure that the DIN rail is already in place
- Move the installation clip at the back of the PMC-230 downward to the “unlock” position
- Mount the PMC-230 on the DIN rail
- Push the installation clip upward to the “lock” position to secure the PMC-230 on to the DIN Rail

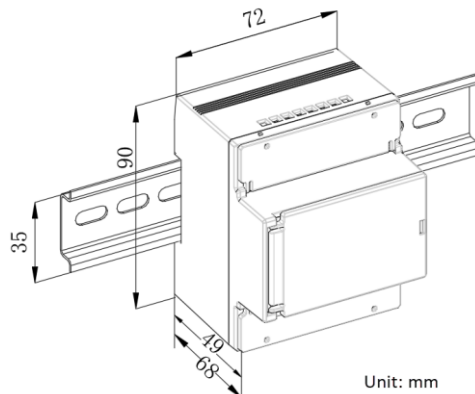

Figure 2-4 Installations

2.5 RS-485 Wiring

The PMC-230 provides one standard RS-485 port that supports the Modbus RTU protocol. Up to 32 devices can be connected on an RS-485 bus. The overall length of the RS-485 cable connecting all devices should not exceed 1200m.

If the master station does not have an RS-485 port, an RS-232/RS-485 or USB/RS-485 converter with optically isolated outputs and surge protection should be used. The following figure illustrates the RS-485 connections on the PMC-230.

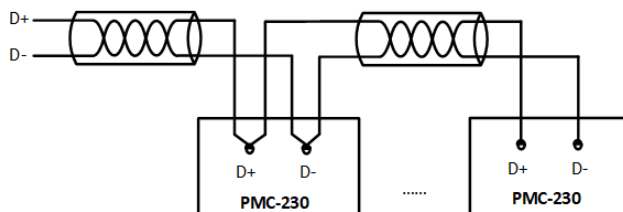

Figure 2-5 RS-485 Wiring

2.6 Digital Input

The following figure illustrates the Digital Input connections:

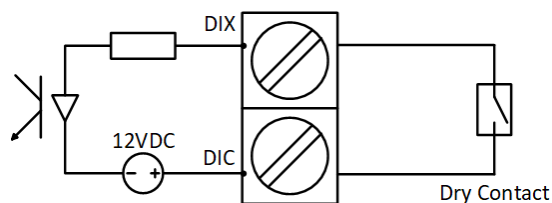

Figure 2-6 Digital Input

2.7 Pulse Output

The following figure illustrates the Solid State Relay connections for Energy Pulsing on the PMC-230 when the **DO Energy Pulse** is programmed for **kWh** or **kvarh** pulsing:

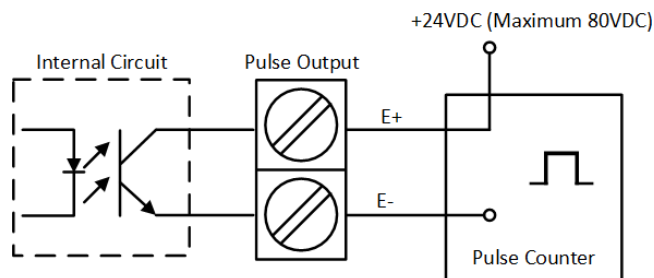

Figure 2-7 Solid State Relay Connections for Energy Pulsing or 1 PPS (Pulse Per Second) Output

Chapter 3 Front Panel

The meter's Front Panel is used for both display and configuration purposes. The LCD display and the two buttons provide access to measurements, meter information and configuration.

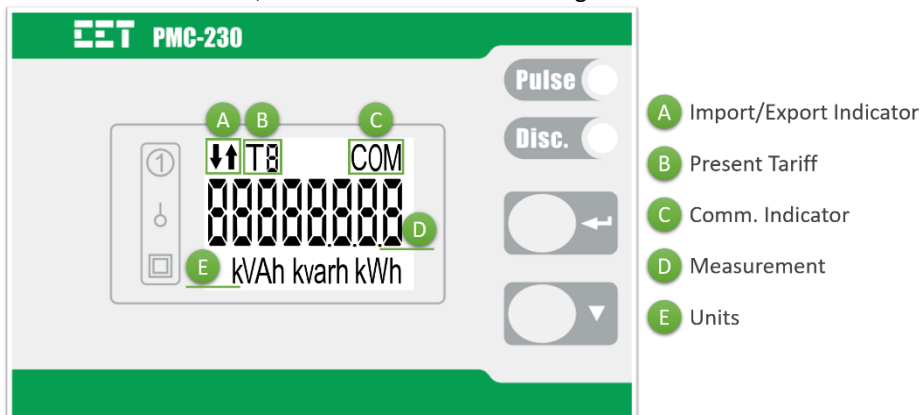

Figure 3-1 Front Panel Display

3.1 LCD Display

3.1.1 LED Pulse Output

The PMC-230 comes standard with an LED Pulse Output on its Front Panel, which can be used for kWh/kvarh Total energy pulsing by setting the **LED** setup parameter via the Front Panel or **LED Energy Pulse** register via communications.

3.1.2 LCD Display Symbols

The following figure shows the LCD display symbols based on "8".

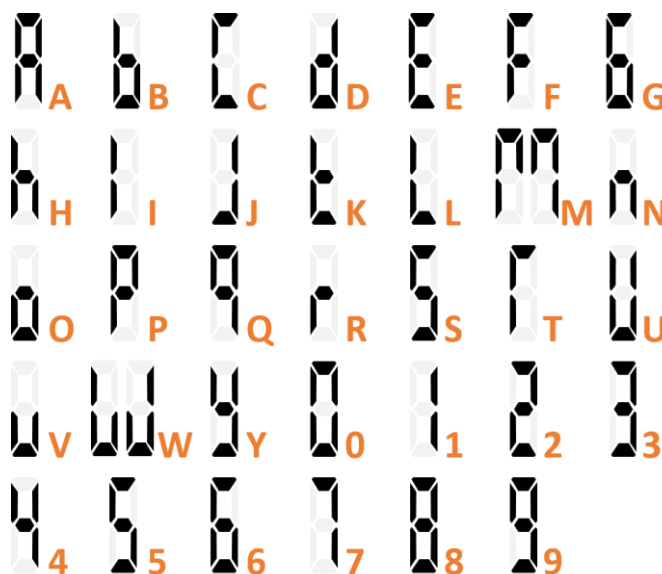

Figure 3-2 LCD Display Symbols

3.2 LCD Testing

Pressing both the <←> and the <▼> buttons simultaneously for 2 seconds enters the **LCD Test** mode. During testing, all LCD segments are illuminated and will blink on and off three times before returning to the **Data Display** mode.

3.3 Display Modes

The PMC-230 has a default display which can be set as one of two modes: **Fixed** mode which displays kWh Imp statically and **Auto-Scroll** mode which displays kWh/kvarh Imp./Exp. and kVAh as well as kWh Imp./Exp. per Tariff sequentially in 4 seconds interval. The **Auto-Scroll** setup parameter can only be enabled/disabled via

communications.

3.4 Data Display

In **Data Display** mode, pressing the <▼> button scrolls to the next parameter while pressing the <←> button toggles among **Energy**, **Real-time Data** and **Counter** menus.

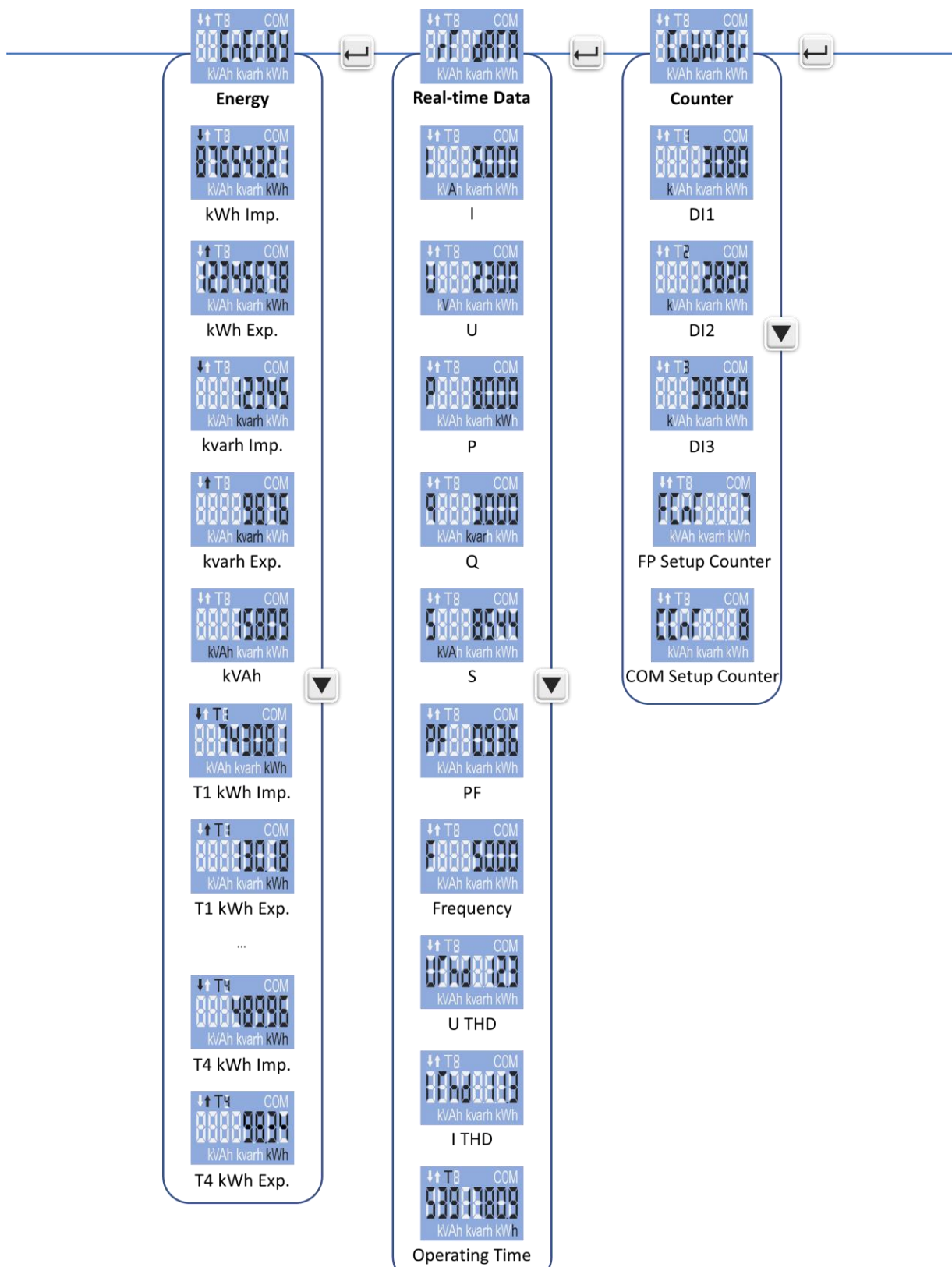

Figure 3-3 Data Display

3.5 Setup Configuration via the Front Panel

Pressing the <↵> button for two seconds enters the **Setup Configuration** mode where the setup parameters can be changed. Upon completion, pressing the <↵> button for two seconds returns to the **Data Display** mode.

3.5.1 Function of buttons

The two Front Panel buttons take on different meanings in the **Setup Configuration** mode and are described below:

- <↵>: Pressing this button for two seconds toggles between **Data Display** mode and **Setup Configuration** mode. Once inside the **Setup Configuration** mode and at the main menu, pressing this button selects a parameter for modification. Once selected, the parameter value blinks while it's being changed. If the selected parameter is a numeric value, pressing this button shifts the cursor to the left by one position. When the cursor has reached the left-most digit, pressing this button again will save the new setting into memory. The parameter will also stop blinking once the value has been saved.
- <▼>: Before an item is selected, pressing this button scrolls to the next setup parameter. If the selected parameter is a numeric value, pressing this button increments the selected digit. If the selected parameter is an enumerated value, pressing this button scrolls through the enumerated list. Pressing the <↵> button will save the current enumerated value.

Making setup changes:

- Press the <↵> button for two seconds to enter the **Setup Configuration** mode.
- Press the <▼> button to advance to the Password page.
- A correct password must be entered before changes are allowed. The factory default password is zero. Press the <▼> button to select the parameter for modification. Use the <▼> and <↵> buttons to enter the correct password.
- Use the <▼> button to scroll to the desired parameter.
- Press the <↵> button to select the parameter. Once selected, the parameter value will blink.
- Use the <↵> and <▼> buttons to make modification to the selected parameter.
- Pressing the <↵> button for two seconds to exit the **Setup Configuration** mode.

3.5.2 Setup Menu

- PROG**
- Enter Front Panel Password
- Set Front Panel Password
- Switch the Disconnect Relay Off/On
- PF Convention
- Comm. ID
- Baudrate
- COM Port Data Format
- No. of Windows
- Demand Period
- LED Energy Pulsing
- DO Energy Pulsing
- Clear Energy
- Clear Demand
- Clear DI Counters
- Clear Operating Time
- Clear SOE
- Clear Setup Counters
- Set Date
- Set Clock
- FW Version
- FW Date
- Protocol Version
- Left 5 digits of SN
- Right 5 digits of SN

Figure 3-4 Setup Menu

3.5.3 Configurations

The Setup Configurations mode provides access to the following setup parameters:

Label	Parameters	Description	Option (value)	Default
PROG	Programming	Setup Configuration Mode	/	/
PW	Password	Enter Password	0~9999	0
SET PW	Set Password	Enter New Password	0~9999	-
DISC	Disconnect	Switch the Disconnect Relay Off/On	ON/OFF	ON
PF	PF Convention	PF Convention	IEC, IEEE, -IEEE	IEC
Id	Unit ID	COM Unit ID	1~247	100
Bd	Baud Rate	Data rate in bits per second (bps)	1200/2400/4800/ 9600/19200	9600
CFG	COM Port Configuration	Data Format	8N2/8O1/8E1/8N1	8E1
nUM	# of Windows	No. of Windows for Demand Calculation	1~15	1
PERlod	Period	Demand Period	0~60 (min)	5(min)
LEd	LED Energy Pulsing	Configure LED Energy Pulsing	OFF/kWh/kvarh	kWh
do	DO Energy Pulsing	Configure DO Energy Pulsing	OFF/kWh/kvarh	kWh
CLr En	Clear Energy	Clear All Energy	YES/No	No
CLr dMd	Clear Demand	Clear All Demand	YES/No	No
CLr DI	Clear DI	Clear All DI counters	YES/No	No
CLr oT	Clear Operating Time	Clear running hours for device	YES/No	No
CLr SoE	Clear SOE	Clear SOE	Yes/No	No
CLr Cnt	Clear Counters	Clear both FP & COM Setup Counters	YES/No	No
	Set Date	Enter the Current Date	YY-MM-DD	/
	Set Clock	Enter the Current Time	HH:MM:SS	/
FW	Firmware Version	Firmware Version	For example, 10002 means the firmware version is V1.00.02.	/
	Firmware Date	Firmware Version Date	YYMMDD	/
PROT	Protocol	Protocol Version	e.g. 1.1 means V1.1	/
SN	The left 5 digits	The left 5 digits of SN	XXXXX	/
	The right 5 digits	The right 5 digits of SN	YYYYY	/

Table 3-1 Configuration

Chapter 4 Applications

4.1 Inputs and Outputs

4.1.1 Digital Inputs

The PMC-230 comes standard with three self-excited Digital Inputs that are internally wetted at 12VDC. Digital Inputs on the PMC-230 can be used in the following applications:

- 1) **Status Input** The digital inputs are typically used for status monitoring which can help prevent equipment damage, improve maintenance, and track security breaches. The real-time statuses of the Digital Inputs are available through communications. Changes in Digital Input status are stored as events in the SOE Log in 1 ms resolution.
- 2) **Pulse Counting** Pulse counting is supported with programmable debounce and pulse weight to facilitate WAGES (Water, Air, Gas, Electricity and Steam) information collection.

The following table describes the DI Setup Parameters that can be programmed over communications:

Setup Parameter	Definition	Options/Default*
Dlx Function	Each DI can be configured as a Status Input or Pulse Counter.	0=Status Input 1=Pulse Counter*
Dlx Debounce	Specifies the minimum duration the DI must remain in the Active or Inactive state before a DI state change is considered to be valid.	1 to 9999 (ms) 20ms*
Dlx Pulse Weight	Specifies the incremental value for each received pulse. This is only used when a DI is configured as a Pulse Counter.	1* to 1,000,000

Table 4-1 Digital Input Setup

4.1.2 Energy Pulse / 1 PPS Output

The PMC-230 comes standard with one Front Panel LED Pulse Output and one Solid State Relay Output for kWh or kvarh Energy Pulsing. Energy Pulse Output is typically used for accuracy testing. Energy Pulsing is enabled by default and can be disabled from the Front Panel or through communications. The Pulse Constant is fixed at 1000 impulses per kWh or kvarh. If the **DO Energy Pulsing (do)** parameter is disabled, the PMC-230 will output a 1PPS signal with a pulse width of 500ms ± 0.5ms at the Energy Pulse Output terminals (**E+**, **E-**) for the accuracy testing of its internal clock.

4.1.3 Disconnect Relay

The PMC-230 comes standard with one internal Disconnect Relay which can be manually operated via the Front Panel or remotely controlled via communications to switch the load off or back on.

4.2 Metering

4.2.1 Basic Measurements

The PMC-230 provides real time measurements for I, U, P, Q, S, PF, Freq., U THD, I THD and Operating Time.

4.2.2 Energy Measurements

The PMC-230 provides Energy measurements for kWh, kvarh Import/Export and kVAh at a resolution of 0.01 kxh and a maximum value of 1,000,000.00 kxh. When the maximum value is reached, it will automatically roll over to zero. The energy measurements can be reset manually via the Front Panel or through communications as well as preset via communications.

4.2.3 Demands

Demand is defined as the average consumption over a fixed interval (usually 15 minutes) based on the sliding window method. The PMC-230 provides the Present Demand, Max. Demand for This Month (Since Last Reset) and Last Month (Before Last Reset) for I, U, P, Q and S. The Present Demand and Max. Demand measurements can be retrieved via communications, and its Setup Parameters can be configured via the Front Panel (except for the **Self-Read Time** parameter) and through communications.

The PMC-230 provides the following Demand Setup parameters:

Parameter	Definition	Options/Default*
Period	1 to 60 minutes. For example, if the # of Sliding Windows is set as 1 and the Demand Period is 15, the demand cycle will be 1×15=15min.	1 to 60 minutes, 5*
# of Sliding Windows	Number of Sliding Windows.	1 to 15, 1*

Self-Read Time	<p>The Self-Read Time allows the user to specify the time and day of the month for the Max. Demand Self-Read operation. The Self-Read Time supports three options:</p> <ul style="list-style-type: none"> • A zero value means that the Self-Read will take place at 00:00 of the first day of each month. • A non-zero value means that the Self-Read will take place at a specific time and day based on the formula: Self-Read Time = Day x 100 + Hour where 0 ≤ Hour ≤ 23 and 1 ≤ Day ≤ 28. For example, the value 1512 means that the Self-Read will take place at 12:00pm on the 15th day of each month. • A 0xFFFF value will disable the Self-Read operation and replace it with manual operation. A manual reset will cause the Max. Demand of This Month to be transferred to the Max. Demand of Last Month and then reset. The terms This Month and Last Month will become Since Last Reset and Before Last Reset. 	0xFFFF*
----------------	--	---------

Table 4-2 Demand Setup

4.2.4 Harmonics

The PMC-230 provides the U THD and I THD measurements which can be retrieved via the Front Panel or through communications. There are two methods for calculating the THD:

THDf:

$$THDf = \frac{\sqrt{\sum_{n=2}^8 I_n^2}}{I_1} \times 100\%$$

where I_1 represents the amplitude of the fundamental component and I_n represents the amplitude of the n^{th} harmonic.

THDr:

$$THDr = \frac{\sqrt{\sum_{n=2}^8 I_n^2}}{\sqrt{\sum_{n=1}^8 I_n^2}} \times 100\%$$

where the denominator represents the total RMS value and the numerator represents the RMS value of the harmonics from 2nd to 8th.

4.3 Logs

4.3.1 Monthly Energy Log

The PMC-230 stores the monthly energy data for the present month and the last 12 months. The **Monthly Energy Log Self-Read Time** setup parameter allows the user to specify the time and day of the month for the Recorder's self-read operation via communications. The Monthly Energy Logs are stored in the meter's non-volatile memory and will not suffer any loss in the event of power failure, and they are stored on a First-in-First-out basis where the newest log will overwrite the oldest one.

The **Monthly Energy Log Self-Read Time** supports two options:

- A zero value means that the Self-Read will take place at 00:00 of the first day of each month.
- A non-zero value means that the Self-Read will take place at a specific time and day based on the formula: Energy Self-Read Time = Day x 100 + Hour where 0 ≤ Hour ≤ 23 and 1 ≤ Day ≤ 28. For example, the value 1512 means that the Self-Read will take place at 12:00 pm on the 15th day of each month.

The Monthly Energy Logs can be reset manually via communications.

The PMC-230 provides the following Energy data for the Present Month and the last 12 months:

Active Energy	kWh Import/Export, Tariff 1 to Tariff 4 kWh Import/Export
Reactive Energy	kvarh Import/Export, Tariff 1 to Tariff 4 kvarh Import/Export
Apparent Energy	kVAh, Tariff 1 to Tariff 4 kVAh

Table 4-3 Energy Measurement for Monthly Energy Log

4.3.2 SOE Log

The PMC-230's SOE Log can store up to 32 events such as Power-on, Power-off, Digital Input Status changes, Disconnect Relay Status changes, Self-diagnostics and Setup changes in its non-volatile memory. Each event record includes the event classification, its relevant parameter values and a timestamp in $\pm 1\text{ms}$ resolution. The SOE Log can be retrieved via communications for display. If there are more than 32 events, the newest event will replace the oldest one on a First-in-First-Out basis. The SOE Log can be reset through the Front Panel or via communications.

4.3.3 Data Recorder Log

The PMC-230 provides one Data Recorder capable of recording 16 parameters at a 5-min interval for 6 months. The Data Recorder log is stored in the device's non-volatile memory and will not suffer any loss in the event of a power failure.

The programming of the Data Recorder is only supported over communications. The Data Recorder provides the following setup parameters.

Parameters	Value/Option	Default
Trigger Mode	0=Disabled / 1=Triggered by Timer	1
Recording Mode	0=Stop-When-Full / 1=First-In-First-Out	1
Recording Depth	1 to 65535 (entry)	60000
Recording Interval	1 to 3,456,000 seconds	300s
Offset Time	0 to 43,200 seconds, 0 indicates no offset.	0
Number of Parameters	0 to 16	14
Parameter 1 to 16	See Table 5-28 Data Recorder Parameters	See Table 5-27 Data Recorder Setup

Table 4-4 Data Recorder Setup

The Data Recorder Log is only operational when the values of Trigger Mode, Recording Depth, Recording Interval, and Number of Parameters are all non-zero.

The Recording Offset can be used to delay the recording by a fixed time from the Recording Interval. For example, if the Recording Interval parameter is set to 3600 (hourly) and the Recording Offset parameter is set to 300 (5 minutes), the recording will take place at 5 minutes after the hour every hour, i.e. 00:05, 01:05, 02:05, etc. The value of the Recording Offset parameter should be less than the Recording Interval parameter.

The following formula can be used to calculate how many bytes would be required for the Data Recorder with n parameters where $0 \leq n \leq 16$.

$$\text{No. of Bytes per Record} = n \times 4 + \text{Timestamp @ 8 bytes}$$

With 16 parameters, the no. of bytes required = $16 \times 4 + 8 = 72$ bytes. It should be noted that the above calculation is used to illustrate the internal organization of the data storage and is only an approximation of the actual implementation. The following table defines the maximum **Recording Depth** can be set for the different number of parameters.

No. of Parameters	Max. Recording Depth	No. of Parameters	Max. Recording Depth
1	65535	9	65535
2	65535	10	65535
3	65535	11	65535
4	65535	12	65535
5	65535	13	65535
6	65535	14	64400
7	65535	15	60600
8	65535	16	57200

Table 4-5 Max. Recording Depth for Different No. of Parameters

4.4 Time of Use (TOU)

TOU is used for Electricity Pricing that varies depending on the time of day, day of week, and season. The TOU system allows the user to configure an electricity price schedule inside the PMC-230 and accumulate energy consumption into different TOU tariffs based on the time of consumption. TOU programming is only supported through communications.

The TOU feature on PMC-230 supports two TOU schedules, which can be switched at a pre-defined time. Each TOU schedule supports:

- Up to 4 Seasons
- 30 Holidays or Alternate Days
- 12 Daily Profiles, each with 8 periods in 15-minute interval
- 4 Tariffs

Each TOU Schedule has the following setup parameters and can only be programmed via communications:

Parameters	Definition	Options
Daily Profile #	Specify a daily rate schedule which can be divided into a maximum of 8 periods in 15-min intervals. Up to 12 Daily Profiles can be programmed for each TOU schedule.	1 to 12, the first period starts at 00:00 and the last period ends at 24:00.
Season #	A year can be divided into a maximum of 4 seasons. Each season is specified with a Start Date and ends with the next season's Start Date.	1 to 4, starting from January 1 st
Alternate Days #	A day can be defined as an Alternate Day, such as May 1 st . Each Alternate Day is assigned a Daily Profile.	1 to 30.
Day Types	Specify the day type of the week. Each day of a week can be assigned a day type such as Weekday1, Weekday2, Weekday3 and Alternate Days. The Alternate Day has the highest priority.	Weekday1, Weekday2, Weekday3 & Alternate Days.
Switching Time	Specify when to switch from one TOU schedule to another. Writing 0xFFFFFFFF to this parameter disables switching between TOU schedules.	Format: YYYYMMDDHH Default=0xFFFFFFFF

Table 4-6 TOU Setup

For each of the 4 Tariffs, the PMC-230 provides the kWh, kvarh Import/Export and kVAh measurement.

Chapter 5 Modbus Map

This chapter provides a complete description of the Modbus register map (**Protocol Version 1.0**) for the PMC-230 to facilitate the development of 3rd party communications driver for accessing information on the PMC-230. The PMC-230 supports the following Modbus functions:

- 1) Read Holding Registers (Function Code 0x03)
- 2) Force Single Coil (Function Code 0x05)
- 3) Preset Multiple Registers (Function Code 0x10)

For a complete Modbus Protocol Specification, please visit <http://www.modbus.org>.

The following table provides a description of the different data formats used for the Modbus registers. The PMC-230 uses the Big Endian byte ordering system.

Format	Description
UINT16/INT16	Unsigned/Signed 16-bit Integer
UINT32/INT32	Unsigned/Signed 32-bit Integer
Float	IEEE 754 32-bit Single Precision Floating Point Number

5.1 Basic Measurements

Register	Property	Description	Format	Scale	Unit
0000	RO	U	Float	x1	V
0002	RO	I	Float		A
0004	RO	P	Float		kW
0006	RO	Q	Float		kvar
0008	RO	S	Float		kVA
0010	RO	PF	Float		--
0012	RO	Frequency	Float		Hz
0014~0039	--	Reserved	--	--	--
0040	RO	FP Counter ¹	UINT16	0~9999	
0041	RO	Comm. Counter ¹	UINT16		
0042	RO	DI Status ²	UINT16		
0043	RO	Disconnect Relay Status ³	UINT16		
0044	RO	Operating Time	UINT32	x0.1	Hour
0046	RO	SOE Log Pointer ⁴	UINT32	--	--
0048	RO	Data Recorder Log Pointer ⁴	UINT32	--	--

Table 5-1 Basic Measurements

Notes:

1. The FP Counter and Comm. Counter will be incremented every time some important setup parameters, which may affect the accuracy of Energy registers and DI Pulse Counters or the way they are calculated, are changed via the Front Panel or communications, respectively. The FP Counter is incremented every time a relevant setup parameter is changed via the Front Panel, while the Comm. Counter is incremented every time a single packet is sent to change one or more relevant setup parameters through communications. The following actions may trigger these counters to increment:
 - Changing Setup Parameters:
 - DI setup parameters
 - LED Energy Pulse
 - DO Energy Pulse
 - Preset Energy Value
 - Demand Period and No. of Sliding Windows
 - TOU setup registers
 - Manual Time Set
 - Clear Actions via the Front Panel:
 - Clear All Energy
 - Clear All Demand
 - Clear Operating Time
 - Clear All DI Counters
 - Clear Actions via communications:
 - Clear Historical Monthly Energy (Register 9600)
 - Clear Real Time Energy (Register 9601)
 - Clear Monthly Energy Log of Present Month (Register 9602)
 - Clear All Energy Logs (Register 9603)
 - Clear Max. Demand Log of This Month (Register 9605)
 - Clear All Demand (Register 9606)
 - Clear Device Operating Time (Register 9607)
 - Clear All Data (Register 9614)
 - Clear DI1 Counter (Register 9609)
 - Clear DI2 Counter (Register 9610)
 - Clear DI3 Counter (Register 9611)
 - Clear All DI Counters (Register 9612)

2. For the DI Status register, the bit values of B0 to B2 represent the states of DI1 to DI3, respectively, with “1” meaning Active (Closed) and “0” meaning Inactive (Open).
3. For the Disconnect Relay Status register, the returned value “1” means Connected while “0” means Disconnected.
4. The PMC-230 has one SOE Log and one DR Log. Each of these logs has a Log Pointer that indicates its current logging position. The range of the Log Pointer is between 0 and 0xFFFFFFFF, and it is incremented by one for every new log generated and will roll over to 0 if its current value is 0xFFFFFFFF. If a Clear Log is performed through the Front Panel or via communications, its Log Pointer will be reset to zero, and the SOE Log Pointer will be immediately incremented by one with a new “Clear SOE” event. When the SOE or DR Log Pointer is larger than the respective Log Depth, the latest 32 SOE logs or up to 65,535 DR Logs are stored on a FIFO basis.

5.2 Real Time Energy Measurements

Register	Property	Description	Format	Scale	Unit
0500	RW	kWh Import	INT32	x0.01	kWh
0502	RW	kWh Export	INT32		
0504	RW	kvarh Import	INT32		kvarh
0506	RW	kvarh Export	INT32		
0508	RW	kVAh	INT32		kVAh
0510	RW	kWh Import of T1	INT32		kWh
0512	RW	kWh Export of T1	INT32		
0514	RW	kvarh Import of T1	INT32		kvarh
0516	RW	kvarh Export of T1	INT32		
0518	RW	kVAh of T1	INT32		...
0520~0538	INT32		kWh
0540	RW	kWh Import of T4	INT32		kWh
0542	RW	kWh Export of T4	INT32		
0544	RW	kvarh Import of T4	INT32		kvarh
0546	RW	kvarh Export of T4	INT32		
0548	RW	kVAh of T4	INT32		kVAh

Table 5-2 Energy Measurements

5.3 DI Pulse Counter

Register	Property	Description	Format	Range/Unit
1200	RW	DI1 Pulse Counter	INT32	0 to 99,999,999
1202	RW	DI2 Pulse Counter	INT32	
1204	RW	DI3 Pulse Counter	INT32	

Table 5-3 DI Pulse Counter

5.4 Harmonic Measurement

Register	Property	Description	Format	Scale/Unit
1300	RO	I THD	Float	x1, 0.1 means 10%
1302	RO	U THD	Float	

Table 5-4 Harmonic Measurements

5.5 Demand Measurements

5.5.1 Present Demand

Register	Property	Description	Format	Scale	Unit
3000	RO	U	Float	x1	U
3002	RO	I	Float		A
3004	RO	P	Float		kW
3006	RO	Q	Float		kvar
3008	RO	S	Float		kVA

Table 5-5 Present Demand

5.5.2 Max. Demand of This Month (Since Last Reset)

Register	Property	Description	Format	Scale	Unit
3400~3405	RO	U	See Table 5-8 Demand Data Structure	x1	U
3406~3411	RO	I			A
3412~3417	RO	P			kW
3418~3423	RO	Q			kvar
3424~3429	RO	S			kVA

Table 5-6 Max. Demand of This Month

5.5.3 Max. Demand of Last Month (Before Last Reset)

Register	Property	Description	Format	Scale	Unit
3600~3605	RO	U	See Table 5-8 Demand Data Structure	x1	U
3606~3611	RO	I			A
3612~3617	RO	P			kW
3618~3623	RO	Q			kvar
3624~3629	RO	S			kVA

Table 5-7 Max. Demand of Last Month

5.5.4 Demand Data Structure

Offset	Format	Description
+0	High-order Byte	Year - 2000 (0-37)
	Low-order Byte	Month (1-12)
+1	High-order Byte	Day (1-31)
	Low-order Byte	Hour (0-23)
+2	High-order Byte	Minute (0-59)
	Low-order Byte	Second (0-59)
+3	INT16	Millisecond (0 to 999)
+4~+5	Float	Record Value

Table 5-8 Demand Data Structure

5.6 Logs

5.6.1 Monthly Energy Log

Register	Property	Description	Format	Scale	Unit
0980	RW	Month ¹	INT16	0 to 12	
0981	RO	High-order Byte: Year (0-37) Low-order Byte: Month (1-12)	INT16	Time Stamp ² (20YY/MM/DD HH:MM:SS)	
0982	RO	High-order Byte: Day (1-31) Low-order Byte: Hour (0-23)	INT16		
0983	RO	High-order Byte: Minute (0-59) Low-order Byte: Second (0-59)	INT16		
0984	RO	kWh Import	INT32		x0.01
0986	RO	kWh Export	INT32	kvarh	
0988	RO	kvarh Import	INT32	kVAh	
0990	RO	kvarh Export	INT32	kWh	
0992	RO	kVAh	INT32	kvarh	
0994	RO	kWh Import of T1 ³	INT32	kVAh	
0996	RO	kWh Export of T1 ³	INT32	...	
0998	RO	kvarh Import of T1 ³	INT32	kWh	
1000	RO	kvarh Export of T1 ³	INT32	kvarh	
1002	RO	kVAh of T1 ³	INT32	kVAh	
1004~1022	RO	...	INT32	...	
1024	RO	kWh Import of T4 ³	INT32	kWh	
1026	RO	kWh Export of T4 ³	INT32	kvarh	
1028	RO	kvarh Import of T4 ³	INT32	kvarh	
1030	RO	kvarh Export of T4 ³	INT32	kVAh	
1032	RO	kVAh of T4 ³	INT32		

Table 5-9 Monthly Energy Log

Notes:

1. This register represents the Month when it is read. To read the Monthly Energy Log, this register must be first written to indicate to the PMC-230 which log to load from memory. The range of this register is from 0 to 12, which represents the Present Month and the Last 12 Months. For example, if the current month is 2016/10, "0" means 2016/10, "1" means 2016/09, "2" means 2016/08, "12" means "2015/10".
2. For each Monthly Energy Log, the time stamp shows the exact self-read time (20YY/MM/DD HH:MM:SS) when the log was recorded. For the Monthly Energy Log of the Present Month, the time stamp shows the current time of the meter because the present month is not yet over.
3. T1 to T4 means Tariff 1 to Tariff 4.

5.6.2 Data Recorder Log

Register	Property	Description	Format	Note
20000	RW	Data Recorder Index	UINT32	See Note 1)
20002	RO	High-order Byte: Year	UINT16	1 to 37 (Year-2000)
		Low-order Byte: Month		1 to 12
20003	RO	High-order Byte: Day	UINT16	1 to 31

		Low-order Byte: Hour		0 to 23
20004	RO	High-order Byte: Minute	UINT16	0 to 59
		Low-order Byte: Second		0 to 59
20005	RO	Millisecond	UINT16	
20006~20007	RO	Parameter 1	Float	
20008~20009	RO	Parameter 2	Float	
20010~20011	RO	Parameter 3	Float	
20012~20013	RO	Parameter 4	Float	
20014~20015	RO	Parameter 5	Float	
20016~20017	RO	Parameter 6	Float	
20018~20019	RO	Parameter 7	Float	
20020~20021	RO	Parameter 8	Float	
20022~20023	RO	Parameter 9	Float	
20024~20025	RO	Parameter 10	Float	
20026~20027	RO	Parameter 11	Float	
20028~20029	RO	Parameter 12	Float	
20030~20031	RO	Parameter 13	Float	
20032~20033	RO	Parameter 14	Float	
20034~20035	RO	Parameter 15	Float	
20036~20037	RO	Parameter 16	Float	

Table 5-10 Data Recorder

Note:

- 1) Writing a value *n* to the Data Recorder Index will load the *n*th Log into the buffer from memory, and the valid range of the DR Index is:
- Between **1** and **DR Log Pointer** when DR Log Pointer ≤ DR Log Depth (see Section 5.9 for DR Log Depth)
 - Between **DR Log Pointer - (DR Log Depth - 1)** and **DR Log Pointer** when the DR Log Pointer > DR Log Depth

5.6.3 SOE Log

The SOE Log Pointer points to the current logging position within the SOE Log where the next event will be stored. The following formula is used to determine the starting register address of the SOE log referenced by a particular SOE Log Pointer value:

$$\text{Register Address} = 10000 + \text{Modulo}[(\text{SOE Log Pointer}-1)/32]*8$$

Register	Property	Description	Format
10000~10007	RO	Event 1	See Table 5-12 SOE Log Data Structure
10008~10015	RO	Event 2	
10016~10023	RO	Event 3	
10024~10031	RO	Event 4	
.....		...	
10248~10255	RO	Event 32	

Table 5-11 SOE Log

SOE Log Data Structure

Offset	Property	Description	Unit
+0	RO	High-order Byte: Event Classification	See Table 5-13 SOE Classification
	RO	Low-order Byte: Sub-Classification	
+1	RO	High-order Byte: Year	0-37 (Year-2000)
	RO	Low-order Byte: Month	1 to 12
+2	RO	High-order Byte: Day	1 to 31
	RO	Low-order Byte: Hour	0 to 23
+3	RO	High-order Byte: Minute	0 to 59
	RO	Low-order Byte: Second	0 to 59
+4	RO	Record Time: Millisecond	0 to 999
+5	RO	High-order Byte: Reserved	-
	RO	Low-order Byte: Status ¹	-
+6	RO	High-order Word: Event Value (Float)	-
+7	RO	Low-order Word: Event Value (Float)	-

Table 5-12 SOE Log Data Structure

Notes:

1. The value “1” means DI Inactive or Disconnect Relay Operated, while the value “2” means DI Active or Disconnect Relay Released.

SOE Classification

Event Classification	Sub-Classification	Status	Event Value	Description
1=DI Changes	1	1/2	0	1=DI1 Inactive, 2=DI1 Active
	2	1/2	0	1=DI2 Inactive, 2=DI2 Active
	3	1/2	0	1=DI3 Inactive, 2=DI3 Active
2=Relay Status	1	1/2	0	1=Relay Operated, 2=Relay Released via Comm.
	2	1/2	0	1=Relay Operated, 2=Relay Released via the Front Panel
4=Self-diagnostic	1	0	0	Flash Fault
	2	0	0	FRAM Fault
	3	0	0	System Parameters Fault
5=Operations	1	0	0	Power On
	2	0	0	Power Off
	3	0	0	Clear All Energy via Front Panel
	4	0	0	Clear All Demand via Front Panel
	5	0	0	Clear All DI Counters via Front Panel
	6	0	0	Clear Operating Time via Front Panel
	7	0	0	Clear SOE via Front Panel
	8	0	0	Clear Setup Counters via Front Panel
	9	0	0	Set Clock via Front Panel
	10	0	0	Setup Changes via Front Panel
	11 to 20	--	--	Reserved
	21	0	0	Clear Real Time Energy via Comm.
	22	0	0	Clear Historical Monthly Energy Log via Comm.
	23	0	0	Clear Present Monthly Energy via Comm.
	24	0	0	Clear All Energy Logs via Comm.
	25	0	0	Clear Max. Demand of This Month via Comm.
	26	0	0	Clear All Demand via Comm.
	27	0	0	Clear All Data via Comm.
	28	0	0	Clear SOE via Comm.
	29	0	0	Clear All DI Counters via Comm.
	30	0	x=1 to 3	Clear DIx Counter via Comm.
	31	0	0	Clear Operating Time via Comm.
	32	0	0	Factory Restore via Comm.
	33	0	0	Setup Changes via Comm.
	34	0	0	Preset Energy via Comm.
	35	0	0	Preset TOU Energy via Comm.
	36	0	1 to 4	Switch TOU Schedule ¹
	37	0	0	Clear Data Recorder via Comm.
	38	0	0	Clear Setup Counters via Comm.
	39	0	0	Set Clock via Comm.
	40	0	0	Communication locked out for 15 minutes after 3 incorrect password attempts!

Table 5-13 SOE Classification

Note:

1. The event values of Switch TOU Schedule are illustrated in the table below:

Record Value	Description
1	Switch Schedule 1 to Schedule 2 manually
2	Switch Schedule 2 to Schedule 1 manually
3	Switch Schedule 1 to Schedule 2 automatically
4	Switch Schedule 2 to Schedule 1 automatically

Table 5-14 TOU Switch Records

5.7 Device Setup

5.7.1 Basic Setup

Register	Property	Description	Format	Range, Default*
6000	WO	Comm. Authorization ¹	UINT16	0~9999
6001	RW	PF Convention	UINT16	0=IEC*, 1=IEEE, 2=-IEEE
6002	RW	THD Calculation ²	UINT16	0= THDf*, 1= THDr
6003	RW	Current Threshold of Device Operating Time	UINT16	1 to 1000 (x0.001 In), 4*
6004	RW	LED Energy Pulse	UINT16	0=Disabled, 1=kWh*, 2=kvarh
6005	RW	Demand Period	UINT16	1 to 60 (min), 5*
6006	RW	No. of Windows	UINT16	1 to 15, 1*
6007	RW	Self-read Time ³	UINT16	0xFFFF*
6008	RW	Monthly Energy Log Self-read Time ⁴	UINT16	100
6009	RW	Default Display ⁵	UINT16	0=kWh Import*, 1=Auto-Scroll
6010	RW	MBPW - Modbus Password ⁶	UINT16	0=Disabled*, 1=Enabled
6011	RW	Comm. Password ⁶	UINT16	0 to 9999, 9999*
6012	RW	Front Panel Password ⁶	UINT16	0 to 9999, 0000*
6013	RW	Arm before execute	UINT16	0=Disabled*, 1=Enabled
6014	RW	Time Zone ⁷	UINT16	0 to 32, 29 (GMT+10:00)*

Table 5-15 Basic Setup

Notes:

1. The Comm. Authorization is the register to which the master software would be required to write the correct Comm. Password before it's allowed to perform any Modbus Read/Write operations with the PMC-230, if the MBPW (Modbus Password) register is enabled. If the Comm. Password is correct, the master software will be able to communicate with the same PMC-230 continually until there is a period of inactivity of 60 seconds or longer. When this happens, the master software will have to write to the Comm. Authorization register again to re-gain access to the PMC-230. If an incorrect Comm. Password has been written to the Comm. Authorization register for 3 consecutive times, Modbus access will be locked out for approximately 15 minutes.

2. There are two ways to calculate THD:

THDf:

$$THDf = \frac{\sqrt{\sum_{n=2}^8 I_n^2}}{I_1} \times 100\%$$

where I_1 represents the amplitude of the fundamental component and I_n represents the amplitude of the n^{th} harmonic.

THDr:

$$THDr = \frac{\sqrt{\sum_{n=2}^8 I_n^2}}{\sqrt{\sum_{n=1}^8 I_n^2}} \times 100\%$$

where the denominator represents the total RMS value and the numerator represents the RMS value of the harmonics from 2nd to 8th.

3. The Self-Read Time applies to the Max. Demand Log and supports the following three options:
- A zero value means that the Self-Read will take place at 00:00 of the first day of each month.
 - A non-zero value means that the Self-Read will take place at a specific time and day based on the formula: Self-Read Time = (Day x 100 + Hour) where $0 \leq \text{Hour} \leq 23$ and $1 \leq \text{Day} \leq 28$. For example, the value 1512 means that the Self-Read will take place at 12:00 pm on the 15th day of each month.
 - A 0xFFFF value means the automatic self-read operation is disabled and replaced with manual operation.
4. The Monthly Energy Log Self-Read Time supports the following options:
- A Zero value means that the Self-Read will take place at 00:00 of the first day of each month,
 - A non-zero value means that the Self-Read will take place at a specific time and day based on the formula: Self-Read Time = (Day x 100 + Hour) where $0 \leq \text{Hour} \leq 23$ and $1 \leq \text{Day} \leq 28$. For example, the value 1512 means that the Self-Read will take place at 12:00 pm on the 15th day of each month.
5. Under **Auto-Scroll** mode, the kWh/kvarh Imp./Exp. and kVAh as well as kWh Imp./Exp. per Tariff are displayed sequentially in 4 seconds interval.
6. The **MBPW** register is disabled by default and should be enabled if communication security is required.
7. The following table lists the Time Zones supported:

Code	Time Zone	Code	Time Zone
0	GMT-12:00	17	GMT+03:30
1	GMT-11:00	18	GMT+04:00
2	GMT-10:00	19	GMT+04:30
3	GMT-09:00	20	GMT+05:00
4	GMT-08:00	21	GMT+05:30
5	GMT-07:00	22	GMT+05:45
6	GMT-06:00	23	GMT+06:00
7	GMT-05:00	24	GMT+06:30

8	GMT-04:00	25	GMT+07:00
9	GMT-03:30	26	GMT+08:00
10	GMT-03:00	27	GMT+09:00
11	GMT-02:00	28	GMT+09:30
12	GMT-01:00	29	GMT+10:00
13	GMT+00:00	30	GMT+11:00
14	GMT+01:00	31	GMT+12:00
15	GMT+02:00	32	GMT+13:00
16	GMT+03:00		

Table 5-16 Time Zones

5.7.2 I/O Setup

Register	Property	Description	Format	Range, Default*
6200	RW	DI1 Function	UINT16	0=Status Input, 1=Pulse Counter*
6201	RW	DI2 Function	UINT16	0=Status Input, 1=Pulse Counter*
6202	RW	DI3 Function	UINT16	0=Status Input, 1=Pulse Counter*
6203	RW	DI1 Debounce	UINT16	1 to 9999ms, 20ms*
6204	RW	DI2 Debounce	UINT16	1 to 9999ms, 20ms*
6205	RW	DI3 Debounce	UINT16	1 to 9999ms, 20ms*
6206	RW	DI1 Pulse Weight	UINT32	1 to 1,000,000, 1*
6208	RW	DI2 Pulse Weight	UINT32	1 to 1,000,000, 1*
6210	RW	DI3 Pulse Weight	UINT32	1 to 1,000,000, 1*
6212	RW	DO Energy Pulse	UINT16	0=Disabled, 1=kWh*, 2=kvarh

Table 5-17 I/O Setup

5.7.3 Communication Setup

Register	Property	Description	Format	Range, Default*
6501	RW	Unit ID	UINT16	1 to 247, 100*
6502	RW	Baud Rate	UINT16	0=1200, 1=2400, 2=4800, 3=9600*, 4=19200,
6503	RW	COM Port Data Format	UINT16	0=8N2, 1=8O1, 2=8E1*, 3=8N1

Table 5-18 Communication Setup

5.8 TOU Setup

5.8.1 Basic

Register	Property	Description	Format	Range, Default*
7000	RO	Current Tariff ¹	UINT16	0=T1*, 1=T2, 2=T3, 3=T4
7001	RO	Current Season	UINT16	0* to 3 (Season #1 to #4)
7002	RO	Current Period	UINT16	0* to 7 (Period #1 to #8)
7003	RO	Current Daily Profile	UINT16	0* to 11 (Daily Profile #1 to #12)
7004	RO	Current Day Type	UINT16	0=Weekday1*, 1=Weekday2 2=Weekday3, 3=Alternate Day
7005	RO	Current TOU Schedule No	UINT16	0=TOU #1*, 1=TOU #2
7006	RW	TOU Switch Time ¹	UINT32	0xFFFFFFFF*
7008	WO	Switch TOU Manually	UINT16	Write 0xFF00 to manually switch the TOU schedule
7009	RW	Sunday Setup	UINT16	0*=Weekday1 1=Weekday2 2=Weekday3
7010	RW	Monday Setup	UINT16	
7011	RW	Tuesday Setup	UINT16	
7012	RW	Wednesday Setup	UINT16	
7013	RW	Thursday Setup	UINT16	
7014	RW	Friday Setup	UINT16	
7015	RW	Saturday Setup	UINT16	

Table 5-19 TOU – Basic Setup

Notes:

1) The following table illustrates the data structure for the TOU Switch Time. For example, 0x1003140C indicates a switch time of 12:00 pm on March 20th, 2016. Writing 0xFFFFFFFF to this register disables the switching between TOU Schedule.

Byte 3	Byte 2	Byte 1	Byte 0
Year-2000 (0-37)	Month (1-12)	Day (1-31)	Hour (00-23)

Table 5-20 TOU Switch Time Format

5.8.2 Seasons

The PMC-230 has two sets of Season setup parameters, one for each TOU. The Base Addresses for the two sets are 7100 and 8100, respectively, where the Register Address = Base Address + Offset. For example, the register address for TOU #1's Season #2's Start Date is 7100+4 = 7104.

Offset	Property	Description	Format	Range/Note
0	RW	Season #1: Start Date ¹	UINT16	0x0101
1	RW	Season #1: Weekday#1 Daily Profile	UINT16	0 to 11
2	RW	Season #1: Weekday#2 Daily Profile	UINT16	
3	RW	Season #1: Weekday#3 Daily Profile	UINT16	
4	RW	Season #2: Start Date	UINT16	High-order Byte: Month Low-order Byte: Day
5	RW	Season #2: Weekday#1 Daily Profile	UINT16	0 to 11
6	RW	Season #2: Weekday#2 Daily Profile	UINT16	
7	RW	Season #2: Weekday#3 Daily Profile	UINT16	
8	RW	Season #3: Start Date	UINT16	See Season #2: Start Date
9	RW	Season #3: Weekday#1 Daily Profile	UINT16	0 to 11
10	RW	Season #3: Weekday#2 Daily Profile	UINT16	
11	RW	Season #3: Weekday#3 Daily Profile	UINT16	
12	RW	Season #4: Start Date	UINT16	See Season #2: Start Date
13	RW	Season #4: Weekday#1 Daily Profile	UINT16	0 to 11
14	RW	Season #4: Weekday#2 Daily Profile	UINT16	
15	RW	Season #4: Weekday#3 Daily Profile	UINT16	

Table 5-21 TOU – Seasons Setup

Notes:

1. **Start Date** for Season #1 is Jan. 1st and cannot be modified.
2. Setting a Season's **Start Date** as 0xFFFF terminates the TOU's Season settings. All subsequent Seasons' setup parameters will be ignored since the previous Season's duration is from its **Start Date** to the end of the year.
3. The **Start Date** of a particular Season must be later than the previous Season's.

5.8.3 Daily Profile

The PMC-230 has two sets of Daily Profile setup parameters, one for each TOU.

Register Address	Property	Description	Format
7200~7215	RW	Daily Profile #1	See Table 5-24 Daily Profile Data Format
7216~7231	RW	Daily Profile #2	
7232~7247	RW	Daily Profile #3	
7248~7263	RW	Daily Profile #4	
7264~7279	RW	Daily Profile #5	
7280~7295	RW	Daily Profile #6	
7296~7311	RW	Daily Profile #7	
7312~7327	RW	Daily Profile #8	
7328~7343	RW	Daily Profile #9	
7344~7359	RW	Daily Profile #10	
7360~7375	RW	Daily Profile #11	
7376~7391	RW	Daily Profile #12	

Table 5-22 TOU #1 – Daily Profile Setup

Register Address	Property	Description	Format
8200~8215	RW	Daily Profile #1	See Table 5-24 Daily Profile Data Format
8216~8359	RW	...	
8360~8375	RW	Daily Profile #11	
8376~8391	RW	Daily Profile #12	

Table 5-23 TOU #2 – Daily Profile Setup

Offset	Property	Description	Format	Note
+0	RW	Period #1 Start Time ¹	UINT16	0x0000
+1	RW	Period #1 Tariff	UINT16	0=T1, ..., 3=T4
+2	RW	Period #2 Start Time	High-order Byte: Hour	0 ≤ Hour < 24
			Low-order Byte: Min	
+3	RW	Period #2 Tariff	UINT16	0=T1, ..., 3=T4
+4	RW	Period #3 Start Time	UINT16	See Period #2 Start Time
+5	RW	Period #3 Tariff	UINT16	0=T1, ..., 3=T4
+6	RW	Period #4 Start Time	UINT16	See Period #2 Start Time
+7	RW	Period #4 Tariff	UINT16	0=T1, ..., 3=T4

+8	RW	Period #5 Start Time	UINT16	See Period #2 Start Time
+9	RW	Period #5 Tariff	UINT16	0=T1, ..., 3=T4
+10	RW	Period #6 Start Time	UINT16	See Period #2 Start Time
+11	RW	Period #6 Tariff	UINT16	0=T1, ..., 3=T4
+12	RW	Period #7 Start Time	UINT16	See Period #2 Start Time
+13	RW	Period #7 Tariff	UINT16	0=T1, ..., 3=T4
+14	RW	Period #8 Start Time	UINT16	See Period #2 Start Time
+15	RW	Period #8 Tariff	UINT16	0=T1, ..., 3=T4

Table 5-24 Daily Profile Data Format

Notes:

- 1) **Daily Profile #1's Period #1 Start Time** is always 00:00 and cannot be modified.
- 2) Setting a Period's **Start Time** as 0xFFFF terminates the Daily Profile's settings. All later Daily Profile' setup parameters will be ignored, and the previous Period's duration is from its **Start Time** to the end of the day.
- 3) The minimum interval of a period is 15 minutes.
- 4) The **Start Time** of a particular Period must be later than the previous Period's.

5.8.4 Alternate Days

Each Alternate Day is assigned a Daily Profile and has a higher priority than Season. If a particular date is set as an Alternate Day, its assigned Daily Profile will override the "normal" Daily Profile for this day according to the TOU settings.

The PMC-230 has two sets of Alternate Days setup parameters, one for each TOU. The Base Addresses for the two sets are 7700 and 8700, respectively, where the Register Address = Base Address + Offset. For example, the register address for TOU #2's Alternative Day #2's Date is 8700+3 = 8703.

Offset	Property	Description	Format	Note
0	RW	Alternate Day #1 Date ¹	UINT32	See Table 5-26
2	RW	Alternate Day #1 Daily Profile	UINT16	0 to 11
3	RW	Alternate Day #2 Date ¹	UINT32	See Table 5-26
5	RW	Alternate Day #2 Daily Profile	UINT16	0 to 11
6	RW	Alternate Day #3 Date ¹	UINT32	See Table 5-26
8	RW	Alternate Day #3 Daily Profile	UINT16	0 to 11
9	RW	Alternate Day #4 Date ¹	UINT32	See Table 5-26
11	RW	Alternate Day #4 Daily Profile	UINT16	0 to 11
12	RW	Alternate Day #5 Date ¹	UINT32	See Table 5-26
14	RW	Alternate Day #5 Daily Profile	UINT16	0 to 11
15	RW	Alternate Day #6 Date ¹	UINT32	See Table 5-26
17	RW	Alternate Day #6 Daily Profile	UINT16	0 to 11
18	RW	Alternate Day #7 Date ¹	UINT32	See Table 5-26
20	RW	Alternate Day #7 Daily Profile	UINT16	0 to 11
21	RW	Alternate Day #8 Date ¹	UINT32	See Table 5-26
23	RW	Alternate Day #8 Daily Profile	UINT16	0 to 11
24	RW	Alternate Day #9 Date ¹	UINT32	See Table 5-26
26	RW	Alternate Day #9 Daily Profile	UINT16	0 to 11
27	RW	Alternate Day #10 Date ¹	UINT32	See Table 5-26
29	RW	Alternate Day #10 Daily Profile	UINT16	0 to 11
...	RW	...	UINT32	...
...	RW	...	UINT16	...
87	RW	Alternate Day #30 Date	UINT32	
89	RW	Alternate Day #30 Daily Profile	UINT16	0 to 11

Table 5-25 TOU – Alternate Days

Notes:

- 1) The following table illustrates the data structure for the Date register:

Byte 3	Byte 2	Byte 1	Byte 0
Reserved	Year-2000 (0-37)	Month (1-12)	Day (1-31)

Table 5-26 Date Format

When the Year and/or Month are set as 0xFF, it means the Alternate Day is repetitive by year and/or month, i.e. the same day of every year or every month is an Alternate Day.

5.9 Data Recorder Setup

Register	Property	Description	Format	Range, Default*
6600	RW	Trigger Mode ¹	UINT16	0=Disabled, 1=Triggered by Timer*
6601	RW	Recording Mode ¹	UINT16	0=Stop-when-Full, 1=First-In-First-Out*
6602	RW	Recording Depth ^{1,3}	UINT16	0 to 65,535, 60000*

6603	RW	Recording Interval ¹	UINT32	1 to 3,456,000s, 300s*
6605	RW	Offset Time ²	UINT16	0* to 43200s
6606	RW	Number of Parameters ^{1, 3}	UINT16	0 to 16, 14*
6607	RW	Parameter #1	UINT16	8 (kWh Import)
6608	RW	Parameter #2	UINT16	9 (kWh Export)
6609	RW	Parameter #3	UINT16	10 (kvarh Import)
6610	RW	Parameter #4	UINT16	11 (kvarh Export)
6611	RW	Parameter #5	UINT16	23 (Disconnect Relay Status)
6612	RW	Parameter #6	UINT16	24 (DI1 Counter)
6613	RW	Parameter #7	UINT16	25 (DI2 Counter)
6614	RW	Parameter #8	UINT16	26 (DI3 Counter)
6615	RW	Parameter #9	UINT16	1 (U)
6616	RW	Parameter #10	UINT16	2 (I)
6617	RW	Parameter #11	UINT16	4 (P)
6618	RW	Parameter #12	UINT16	3 (Freq.)
6619	RW	Parameter #13	UINT16	13 (U Demand)
6620	RW	Parameter #14	UINT16	14 (I Demand)
6621	RW	Parameter #15	UINT16	0 (Null)
6622	RW	Parameter #16	UINT16	0 (Null)

Table 5-27 Data Recorder Setup

Notes:

1. Changing any of these Data Recorder setup registers will reset the Data Recorder.
2. **Recording Offset** can be used to delay the recording by a fixed amount of time from the **Recording Interval**. For example, if the **Recording Interval** is set to 3600 (hourly) and the **Recording Offset** is set to 300 (5 minutes), the recording will take place at 5 minutes after the hour every hour, i.e. 00:05, 01:05, 02:05...etc. The value of the **Recording Offset** parameter should be less than the **Recording Interval** parameter.
3. Please refer to **Section 4.3.3** to configure the **Recording Depth** and **Number of Parameters**.
4. Please refer to the following table for a complete list of Data Recorder Parameters.

ID	Parameter	Format	ID	Parameter	Format	ID	Parameter	Format
0	Null	--	9	kWh Export	INT32	18	U Max Demand	Float
1	U	Float	10	kvarh Import	INT32	19	I Max Demand	Float
2	I	Float	11	kvarh Export	INT32	20	kW Max Demand	Float
3	Freq.	Float	12	kVAh	INT32	21	kvar Max Demand	Float
4	kW	Float	13	U Demand	Float	22	kVA Max Demand	Float
5	kvar	Float	14	I Demand	Float	23	Disconnect Relay Status	INT32
6	kVA	Float	15	kW Demand	Float	24	DI1 Counter	INT32
7	PF	Float	16	kvar Demand	Float	25	DI2 Counter	INT32
8	kWh Import	INT32	17	kVA Demand	Float	26	DI3 Counter	INT32

Table 5-28 Data Recorder Parameters

5.10 Time

There are two sets of Time registers supported by the PMC-230 – Year / Month / Day / Hour / Minute / Second (Registers # 60000 to 60002) and UNIX Time (Register # 60004). When sending time to the PMC-230 over Modbus communications, care should be taken to only write one of the two Time register sets. All registers within a Time register set must be written in a single transaction. If registers 60000 to 60004 are being written to at the same time, both Time register sets will be updated to reflect the new time specified in the UNIX Time register set (60004) and the time specified in registers 60000-60002 will be ignored. Writing to the Millisecond register (60003) is optional during a Time Set operation. When broadcasting time, the function code must be set to 0x10 (Pre-set Multiple Registers). Incorrect date or time values will be rejected by the meter. In addition, attempting to write a Time value less than Jan 1, 2000, 00:00:00 will be rejected.

Register	Property	Description	Format	Note
60000	9000	RW	UINT16	0-37 (Year-2000)
		High-order Byte: Year		1 to 12
60001	9001	RW	UINT16	1 to 31
		High-order Byte: Day		0 to 23
60002	9002	RW	UINT16	0 to 59
		Low-order Byte: Hour		0 to 59
60003	9003	RW	UINT16	0 to 999
60004 ~ 60005	9004 ~ 9005	RW	UINT32	0x386D4380 to 0x7FE8177F The corresponding time is 2000.01.01 00:00:00 to 2037.12.31 23:59:59 (GMT+00:00 Time Zone)

Table 5-29 Time Registers

Note:

- 1) The UNIX time in GMT+00:00 Time Zone should be used when writing the meter's time. The meter will compute internally and display in Local Time based on the setting of the Time Zone setup register (#6014).

5.11 Remote Control

The Remote Control registers are implemented as both "Write-Only" Modbus Coil Registers (0XXXXX) and Modbus Holding Registers (4XXXXX), which can be controlled with the Force Single Coil command (Function Code 0x05) or the Preset Multiple Hold Registers (Function Code 0x10). The PMC-230 does not support the Read Coils command (Function Code 0x01) because Remote Control registers are "Write-Only". The Disconnect Relay Status register 0043 should be read instead to determine the current Disconnect Relay status.

The PMC-230 adopts the ARM before EXECUTE operation for the remote control of its Internal Disconnect Relay if this function is enabled through the **Arm Before Execute** Setup register (6013), which is disabled by default. Before executing an OPEN or CLOSE command on the Disconnect Relay, it must be "Armed" first. This is achieved by writing the value 0xFF00 to the appropriate register to "Arm" a particular operation. The Relay will be "Disarmed" automatically if an "Execute" command is not received within 15 seconds after it has been "Armed". If an "Execute" command is received without first having received an "Arm" command, the meter ignores the "Execute" command and returns the 0x04 exception code.

Register	Property	Description	Format	Note
9100	WO	Arm Disconnect Relay Close	UINT16	Writing "0xFF00" to the register to perform the described action.
9101	WO	Execute Disconnect Relay Close	UINT16	
9102	WO	Arm Disconnect Relay Open	UINT16	
9103	WO	Execute Disconnect Relay Open	UINT16	

Table 5-30 Remote Control

5.12 Clear/Reset Control

Register	Property	Description	Format	Note
9600	WO	Clear Historical Monthly Energy Log ¹	UINT16	Writing "0xFF00" to the register execute the described action.
9601	WO	Clear Real Time Energy ²		
9602	WO	Clear Present Monthly Energy Log		
9603	WO	Clear All Energy ³		
9604	WO	Clear Setup Counters ⁴		
9605	WO	Clear Max. Demand Log of This Month ⁵		
9606	WO	Clear All Demand ⁶		
9607	WO	Clear Device Operating Time		
9608	WO	Clear SOE		
9609	WO	Clear DI1 Pulse Counter		
9610	WO	Clear DI2 Pulse Counter		
9611	WO	Clear DI3 Pulse Counter		
9612	WO	Clear All DI Pulse Counters		
9613	WO	Clear Data Recorder Logs		
9614	WO	Clear All Data ⁷		

Table 5-31 Clear/Reset Control

Notes:

1. Writing 0xFF00 to the **Clear Historical Monthly Energy** Log register to clear the Monthly Energy Log of the Last 1 to 12 months, excluding the Present Monthly Energy Log.
2. Writing 0xFF00 to the **Clear Real Time Energy** register to clear kWh, kvarh Import/Export and kVAh as well as the TOU kWh, kvarh Import/Export and kVAh energy measurements.
3. Writing 0xFF00 to the **Clear All Energy** register to clear the Energy measurements and all Monthly Energy logs (Present + 12 Historical).
4. Writing 0xFF00 to the **Clear Setup Counters** to clear the Front Panel Setup Counter and COM Setup Counter.
5. Writing 0xFF00 to the **Clear Max. Demand of This Month** register to clear the Max. Demand Log of This Month (Since Last Reset) when the **Self-Read Time** register is configured for automatic Self-Read operation. The Max. Demand of Last Month will not be cleared. If the **Self-Read Time** register is configured for manual operation with a register value of 0xFFFF, the Max. Demand of This Month (Since Last Reset) will be transferred to the Max. Demand of Last Month (Before Last Reset) and then cleared.
6. Writing 0xFF00 to the **Clear All Demand** register to clear the Present Demand, Max. Demand of This/Last Month.
7. Writing 0xFF00 to the **Clear All Data** register to clear All Energy (Energy Measurements and all Monthly Energy Logs), Setup Counters, All Demands, Device Operating Time, SOE, DI Pulse Counters and Data Recorder Logs.

5.13 Meter Information

Register	Property	Description	Format	Note
60200~60219	9800~9819	RO	UINT16	See Note 1)
60220	9820	RO	UINT16	e.g. 10000 shows the version is V1.00.00
60221	9821	RO	UINT16	e.g. 10 shows the version is V1.0

60222	9822	RO	Firmware Update Date: Year-2000	UINT16	e.g. 140110 means January 10, 2014
60223	9823	RO	Firmware Update Date: Month	UINT16	
60224	9824	RO	Firmware Update Date: Day	UINT16	
60225	9825	RO	Serial Number	UINT32	

Table 5-32 Meter Information

Note:

- 1) The Meter Model Appears from registers 60200 to 60219 and contains the ASCII encoding of the string "PMC-230" as shown in the following table.

Register	Value (Hex)	ASCII
60200	0x50	P
60201	0x4D	M
60202	0x43	C
60203	0x2D	-
60204	0x32	2
60205	0x33	3
60206	0x30	0
60207-60219	0x20	Null

Table 5-33 ASCII Code for "PMC-230"

Appendix A – Technical Specification

Measurement Inputs (L, N, L', N')			
Voltage (Un)	220VAC	230VAC	240VAC
Overrange (% Un)	120%	115%	110%
Range	95-264VAC		
Burden	<3VA		
Current (Ib / I _{max})	5A / 63A		
Starting Current	0.4% Ib (20mA)		
Minimum Current	5% Ib (0.25A)		
Burden	<3VA		
Frequency	50Hz/60Hz		
Power Supply	Self-powered from 95 to 264VAC		
Maximum Wire Size	25 mm ² (4AWG)		
Torque for L, N Terminals	2.5 N.m		
Disconnect Relay			
Rated Load (Resistive)	100A @ 250VAC		
Response Time	20ms		
Short-time Overcurrents	7000A (-10% to +0%) @ 60ms		
Service Life (Mech./Elec.)	100k/5k Operations		
Rated Making Capacity @ 1.15Un and PF=1	63A max.		
Rated Breaking Capacity @ 1.15Un and PF=1	63A max.		
Dielectric (AC Voltage)	4kV @ 1minute (Contact to Coil) 2kV @ 1minute (Contact to Contact)		
Insulation Resistance	1000MΩ/500VDC		
SSR Pulse Output (E+, E-)			
Type	Optically Isolated Solid State Relay		
Max. Load Voltage	80 VDC		
Max. Forward Current	50 mA		
Maximum Wire Size	1.5 mm ² (16AWG)		
Torque for E+, E- Terminals	0.45 N.m		
Communications (D+, D-)			
RS-485 (Modbus RTU)	Optically isolated @ 5kVrms		
Maximum Wire Size	1.5mm ² (16AWG)		
Torque for RS-485 Terminals	0.45 N.m		
Digital Inputs (DI1, DI2, DI3, DIC)			
Type	Dry Contact, 12VDC internally wetted		
Sampling	1000Hz		
Hysteresis	1ms minimum		
Environmental Conditions			
Operating Temp.	-25°C to +70°C		
Storage Temp.	-40°C to +85°C		
Humidity	5% to 95% non-condensing		
Atmospheric pressure	70kPa to 106kPa		
Pollution Degree	2		
Mechanical Characteristics			
Unit Dimensions	72(W)x68(D)x90(H)mm		
Mounting	DIN-Rail Mounting		
IP Rating	IP51 (Front) IP30 (Body)		

Accuracy

Parameters	Accuracy	Resolution
Voltage	±0.5%	0.1V
Current	±0.5%	0.001A
P, Q, S	±1.0%	0.001kW/kvar/kVA
kWh	IEC 62053-21 Class 1	0.01kWh
kvarh	IEC 62053-23 Class 2	0.01kvarh
PF	±1.0%	0.001
Frequency	±0.02Hz	0.01Hz

Appendix B – Standards of Compliance

Safety Requirements	
CE LVD 2014/35/EU	EN 61010-1: 2010 EN 61010-2-030: 2010
Electrical safety in low voltage distribution systems up to 1000Vac and 1500 Vdc	IEC 61557-12: 2018 (PMD)
Insulation	IEC 62052-11: 2003 IEC 62053-21: 2003 NMI M6-1
AC voltage	4kV @ 1 minute
Impulse voltage	12kV+0%, -15%, 1.2/50µs (NMI M6-1)
Electromagnetic Compatibility EMC 2014/30/EU (EN 61326: 2013)	
Electrostatic discharge	EN 61000-4-2: 2009
Radiated fields	EN 61000-4-3: 2006+A1: 2008+A2: 2010
Fast transients	EN 61000-4-4: 2012
Surges	EN 61000-4-5: 2014+A1: 2017
Conducted disturbances	EN 61000-4-6: 2014
Magnetic Fields	EN 61000-4-8: 2010
V Dips, Interruptions & Variations	EN 61000-4-11: 2004+A1: 2017
Mechanical Tests	
Spring hammer test	IEC 62052-11: 2003
Vibration Test	IEC 62052-11: 2003
Shock Test	IEC 62052-11: 2003
Revenue Metering Approval	
NMI M6-1 of Australia	Approval Mark: NMI 14/2/109 UL Ref. # R4789222180_NMI

Appendix C – Ordering Guide

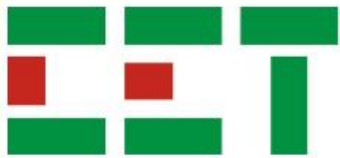
		CET Electric Technology	<i>Version 20200627</i>					
Product Code		Description						
PMC-230 Single-Phase Multifunction Energy Meter								
Basic Function								
B	4MB Memory, 1xData Recorder, 3xDI, 1xLED Pulse Output, 1xSS Pulse Output, 1xRS-485 and an Internal UC3 Compliant Disconnect Relay							
Input Current								
C	5A (63A Max.), Direct Input							
Input Voltage								
3	95V-240VAC, ±10%							
System Frequency								
5	50Hz/60Hz							
Communications								
A	1xRS-485							
Language								
E	English							
PMC-230	-	B	C	3	5	A	E	PMC-230-BC35AE (Standard Model)

Contact us

CET Electric Technology Inc.

Email: Support@cet-global.com

Web: www.cet-global.com